

STONE MASON™ ARCHITECTURAL SERIES



 **AMCON**®

STONE MASON™ ARCHITECTURAL SERIES

Stone Mason™ Series CMUs provide the timeless look of natural weathered stone with the strength and economy of a concrete masonry unit system. The multi-sized, classic hewn appearance of the Stone Mason series make it ideal for “brick-or-better” specifications.

- Simulates natural stone sizes, but in a modular unit which is compatible with conventional wall construction methods.
- Available in both full-height and half-height options in both veneer and structural depths.
- Available in over 40 solid and variegated/blended colors or work with our team to create your own signature color blend.
- Manufactured using Amcon™ EnviroTrol™ curing system to ensure completely hydrated, fully-cured, pre-shrunk units to reduce the potential for efflorescence.
- Also available using Amcon™ Sustainable Solutions mix design for eco-friendly or LEED projects.

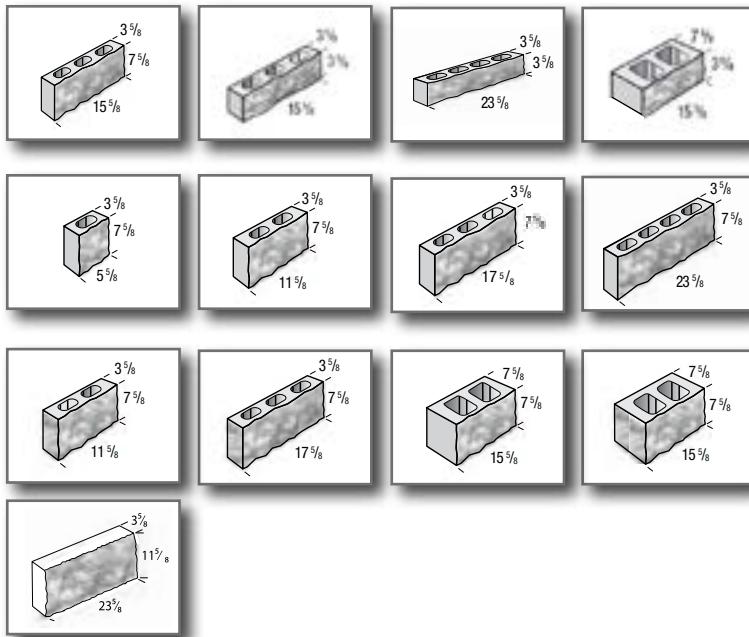

LOCATIONS

AMCON • ST. CLOUD
2211 Highway 10 South
St. Cloud, MN 56304
320.251.6030

AMCON • ST. JOSEPH
8644 Ridgewood Road
St. Joseph, MN 56374
320.363.0905

AMCON • SIOUX FALLS
101 Industrial Road
Harrisburg, SD 57032
605.330.8481

AMCON • ANNANDALE
12052 Highway 24
Annandale, MN 55302
320.274.5587

AMCON • MEDFORD
2173 NW 76th Street
Medford, MN 55049
507.451.7278

TCC BLOCK • RAPID CITY
3292 Lien Street
Rapid City, SD 57702
605.342.6070



2025 Centre Pointe Blvd, Suite 300
Mendota Heights, MN 55120
651.688.9116 • amconconcreteproducts.com